

Installation Instructions

engine management system trijekt plus

trijekt GmbH
Triftstr. 56
57258 Freudenberg
Phone: +49 2734 / 571333
Fax: +49 2734 / 20976
e-mail: info@trijekt.de
www.trijekt.de



**Installation Instructions
engine management system
trijekt plus**

**Version 1.00R1
06.06.2011
Page 2/31**

Index

	Page
1 Installation - Preamble.....	5
1.1 introduction.....	5
1.2 safety instructions.....	6
2 Installation.....	7
2.1 cable harness.....	7
2.2 trijekt – Control Unit.....	8
2.2.1 fixing.....	8
2.2.2 electrical connection, current supply, fuel pump, rev counter.....	10
2.2.3 electrical connection, computer connection.....	11
2.3 throttle potentiometer.....	12
2.3.1 fixing.....	12
2.3.2 electrical connection.....	13
2.4 speed sensor.....	13
2.4.1 fixing.....	14
2.4.2 electrical connection.....	14
2.5 temperature sensors.....	15
2.5.1 fixing.....	15
2.5.2 electrical connection.....	16
2.6 fuel injectors.....	17
2.7 ignition module / ignition driver / ignition coils.....	18
2.7.1 fixing.....	18
2.7.2 electrical connection.....	19

Index

	Page
2.8	lambda oxygen sensor..... 20
2.8.1	fixing..... 20
2.8.2	electrical connection..... 21
2.9	idle controller..... 23
2.10	boost pressure sensor / intake manifold sensor / ext. air pressure 24
2.11	air-mass sensor..... 25
2.12	boost pressure valve..... 26
2.13	accelerator pedal & drive by wire throttle..... 27
2.14	stepping motor..... 27
2.15	CAN-Bus..... 28
2.16	exhaust gas temperature..... 29
2.17	additional inputs (aux, gear shift, function input)..... 30
2.18	switching outputs..... 31

1. Installation - Preamble

1.1 introduction

These installation instructions will support you in installing and running our **trijekt** control unit.
For most positionings you get clear and detailed information.

Nevertheless, we kindly request you to consider the following notes:

trijekt can work perfectly only if installation of the components and of the electrical connections is carried out with due care.

So please read this installation instruction carefully, **before** starting installation and keep it for future application.

In many places installation requires an extensive expert knowledge, experience and craftsmanship. For this reason you should install the control unit on your own **only** in case that

- you dispose of the necessary knowledge and experience as motor mechanic or car electrician personally,
- in cases of doubt you can take expert advice.

In all other cases please charge competent experts with the installation of the control unit – experienced tuners or a specialized garage!

Please note that **trijekt** GmbH will not assume liability for any damages caused by improper self installation or incorrect handling of the control unit.

1. Installation - Preamble

1.2 safety instructions

Before installing the control unit **it is imperative** to consider the following warning notices:

Preface	<p>For installation of the control unit you have to dispose of extensive expert knowledge. Improper procedure during installation can cause damage or destruction of the connected engine. In case of doubt please contact an expert prior before!</p>
Installation	<p>During installation and connection of trijekt disconnect the vehicle battery!</p> <p>Thereby it is imperative to consider all safety instructions of the vehicle producer (e.g. concerning airbag, alarm system, on-board computer, immobiliser system). Caution working at the fuel system! At all costs you have to avoid smoking, open flames and unshielded candles! Make provisions against flying sparks and static electricity! Especially pay attention that there won't arise any leakages, since even slight leakages in the area of engine and exhaust system represent fire danger or explosion risk!</p> <p>When drilling holes please take care that no vehicle parts (battery, cables, hoses etc.) will be damaged!</p> <p>Don't lay cable connections (especially in the engine compartment) in areas being at risk of splash water.</p> <p>According to our experience soldering the crimp connections has turned out to be rather a source of defect than to be useful. Due to engine vibrations connections break more easily at soldered contacts.</p> <p>Please fix the cable harness and signal transmitter in the way that they are not situated near rotating or moving engine parts (danger of chafe marks).</p>
Operation	<p>Before using your vehicle equipped with our trijekt Engine Management Unit in road traffic, this installation has to be approved by an authorized test centre. This approval must be registered in the motor vehicle registration certificate.</p> <p>Please note that you lose any insurance coverage in case of using trijekt in road traffic without approval!</p>

2. Installation

2.2 cable harness

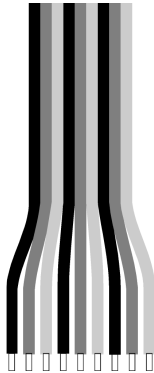

For installing the cable harness please proceed as follows:

- Pass the single cables of the cable harness to the corresponding sensors in the engine compartment, according to connecting diagram. Please take care that there do not occur any breaks or rubbing points thereby.
- Tie the individual cables up in one direction with cable clips.
- Fasten the cable harnesses at appropriate places on the body. Please avoid direct neighbourhood of ignition cables and ignition coils.
- Remove the cable casing abt. 10 cm before the respective sensor. Do not at all damage the individual lines of the cable!
- Shrink an approx. 3 to 4 cm long piece of heat shrink tube on protective cover and cable.
- Skin the individual lines.
- Install the corresponding plugs.



Please note that the control unit can only work properly in case of a good earth connection of the cable harness.

Have utmost attention to earth connection, since high currents use to flow here!

The cable colours indicated in this chapter are based on our standard cable harness!

2. Installation

2.2 trijekt – control unit

2.2.1 fixing



Install the control unit preferably in a protected place inside the vehicle, (e. g. below the instrument panel or on the side in the foot space.)

Fix the control unit with two screws at the notches provided.

Please make sure that enough space for the main plug of the **trijekt** cable harness is available.



Please mind hidden hollow spaces when drilling the holes and turning in the fixing screws!

In any case do not damage any vehicle parts such as cable harnesses laid in the hollow spaces, hoses or lines!

2. Installation

scale drawing / drill template

fixing screw: M5

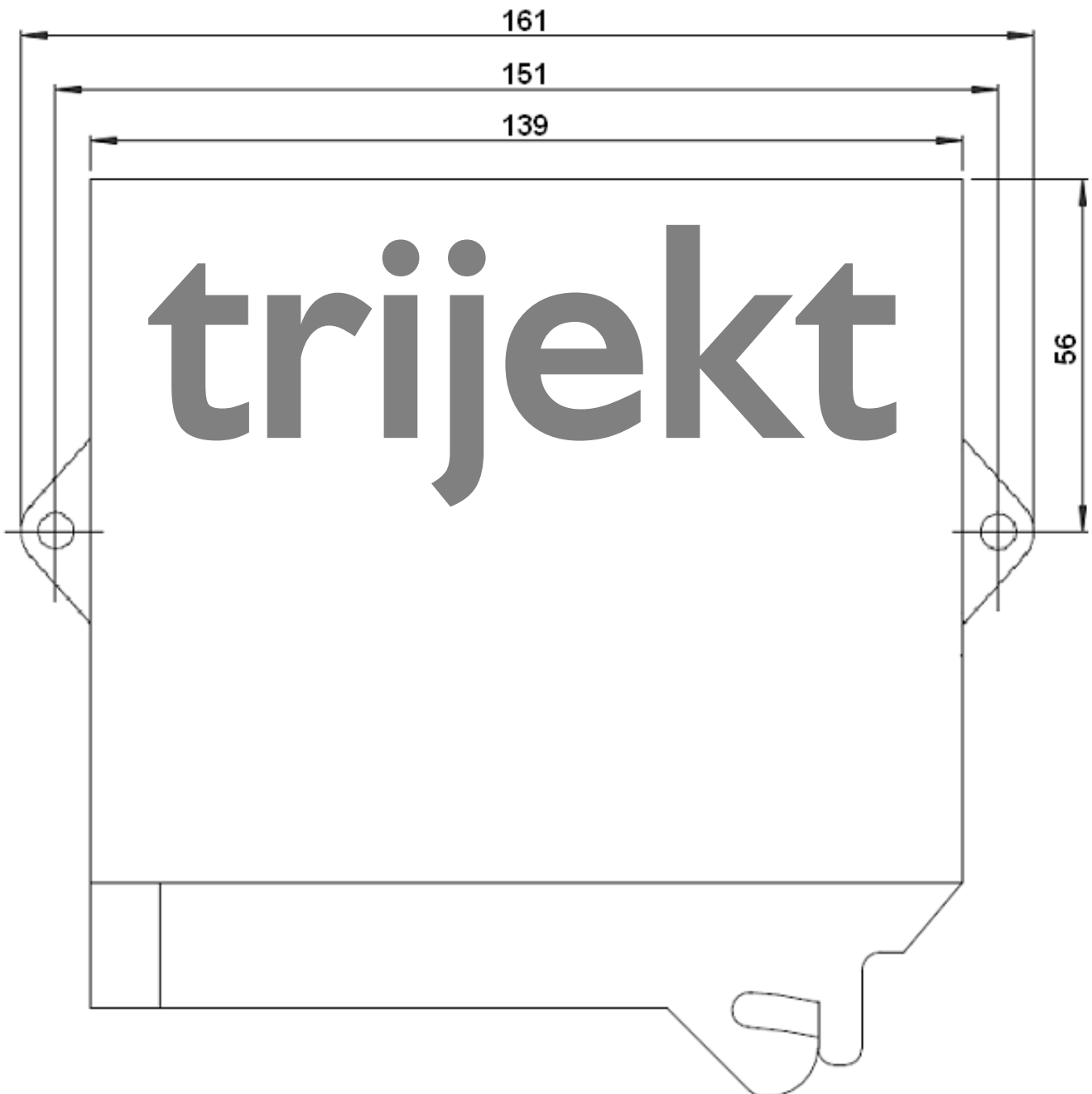

scale 1:1

2. Installation

2.2.2 electrical connection, current supply, fuel pump, rev counter

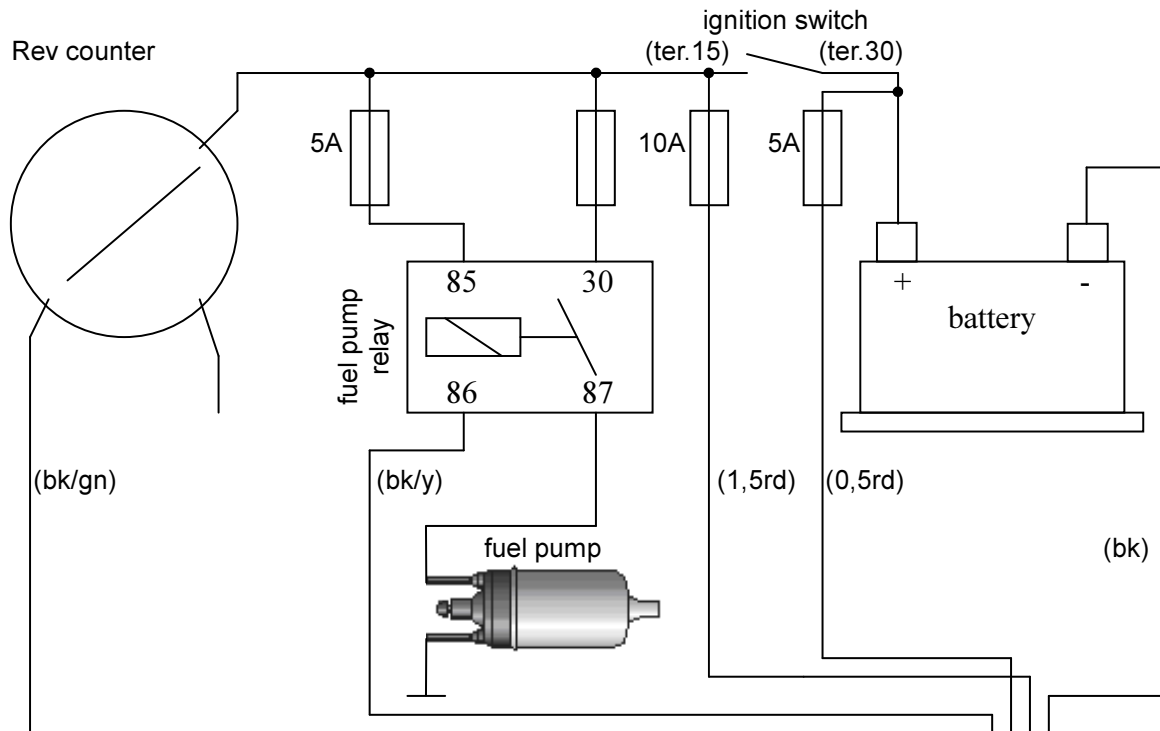

- rev counter signal not suitable for all rev counters!
- When using a battery disconnecting switch please take care of a proper Installation of the resistor in order to divert overvoltage of the electric generator!
- Basically, the fuel pump must be switched via relay! **Danger of Destruction!**

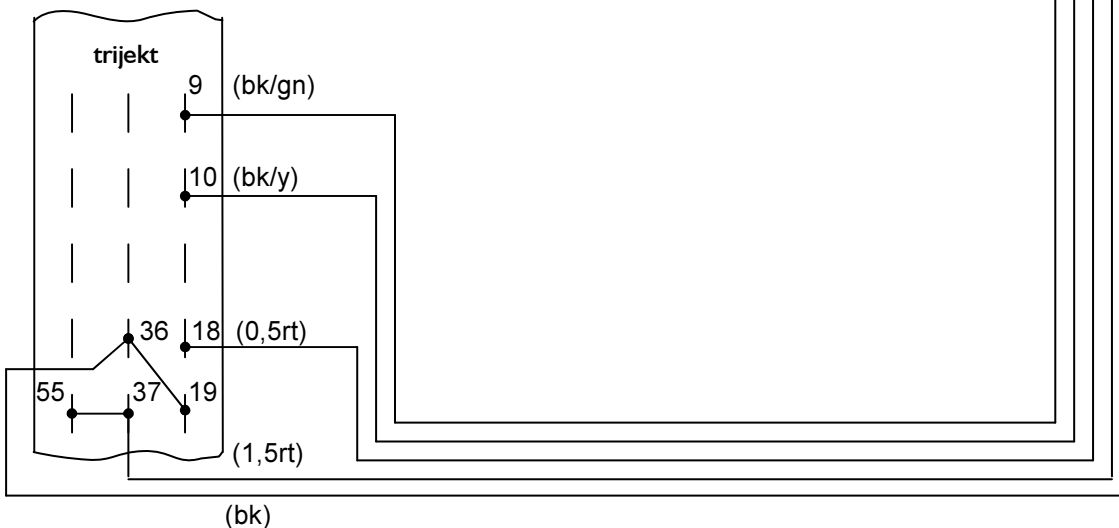

2. Installation

2.2.3 electrical connection, computer connection

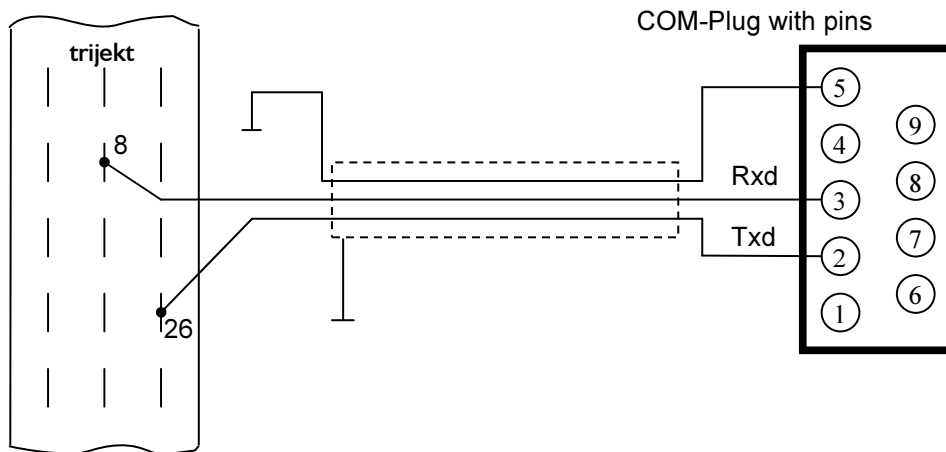

connection to computer is effected via a null modem cable!

2. Installation

2.3 throttle potentiometer

2.3.1 fixing

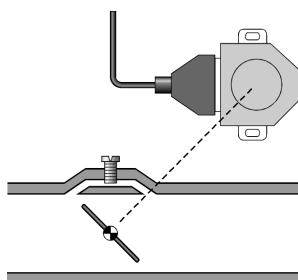

Should the vehicle to be changed over already be equipped as standard with a potentiometer at the throttle, this one can be taken over without hesitation. However, many vehicles dispose of one throttle switch only, that optically can't be distinguished from a potentiometer. Therefore, it is absolutely necessary to check the potentiometer function by means of a resistance measuring instrument.

In case that the vehicle to be changed over disposes of one switch only, this has to be displaced by a potentiometer as identical in construction as possible.

Shouldn't the throttle dispose of a fixation for the potentiometer, a suitable mounting has to be constructed.

Please build the mounting of the throttle potentiometer considering the following points:

- The potentiometer has to be placed centrally on the throttle shaft.
- The bearing face must be at right angle with the axis.
- The mounting flange has to be installed on the throttle body vibration-free.
- In no case the potentiometer may act as a stop for the throttle.
- Being very delicate, all installation- and subsequent operating movements of the potentiometer have to be carried out absolutely smooth-running. However, direction of rotation and basic position are irrelevant, since they will be adjusted via software later

2.3.2 electrical connection

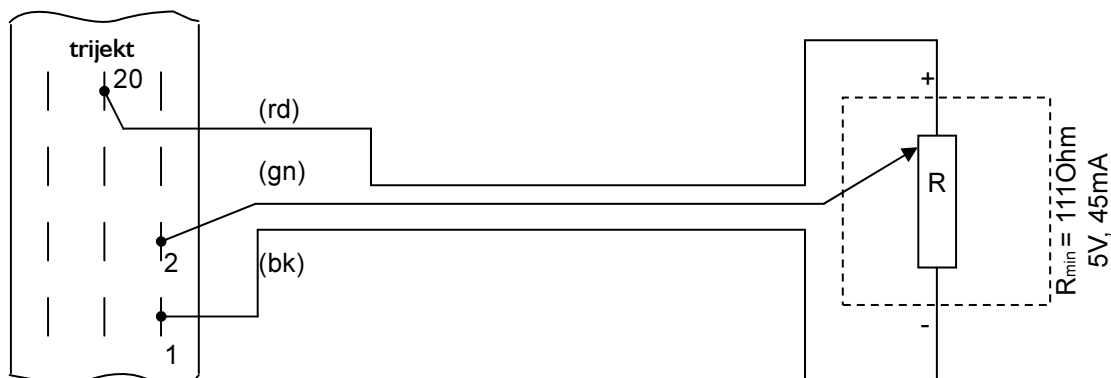

- pay attention to interference when connecting several sensors.

2. Installation

2.4 speed sensor

2.4.1 fixing

trijekt supports different ways of speed measurement. Depending on the used ignition system (distributor ignition system, one coil per cylinder, double-spark coil) the following combinations are possible:

- Hall-/Inductive sensor in series with mechanical high-voltage distribution
- Inductive sensor via gear rim at the crankshaft or camshaft in connection with a static high-voltage distribution.

Hall-/Inductive sensor with mechanical high-voltage distribution

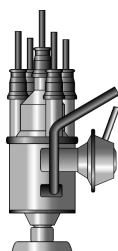

A serial hall/inductive sensor in the distributor can be adopted unchanged.

Considering its polarity this distributor is connected to the control unit according to connecting diagram.

Inductive sensor with static high-voltage distribution

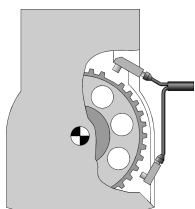

In case that static high-voltage distribution is used for installation (i. e. one coil per cylinder or double-spark coil for two cylinders), the control unit must be able to detect the crankshaft position in order to control the suitable ignition coil respectively. This is only possible by means of a gear rim at crankshaft and camshaft.

- For this purpose please apply a gear wheel releasing 20 to 50 impulses per engine rotation. Having good magnetic properties, soft iron should be used preferably. Available sensor systems of already existing equipments can be taken over as a matter of course.
- Remove a tooth at abt. 60-90 ° before dead centre of the first cylinder. By means of this gap the control unit identifies the current engine position.



Good results have been achieved installing an inductive sensor in the area without toothed belt beneath the camshaft gear wheel. Thereby one resp. two teeth are ground off centrally abt. 1 cm wide, which doesn't weaken the belt drive.

Camshaft sprocket with tooth ground off half

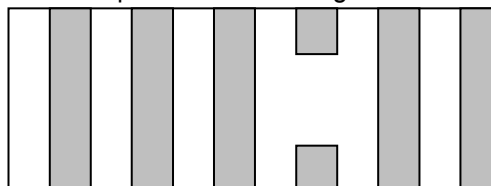

In case that the engine is equipped with one sensor at the crankshaft only, it can be operated semi-sequentially only.

Having a sensor at the camshaft, it can be operated both semi- and fully sequentially.

2. Installation

2.4.2 electrical connection

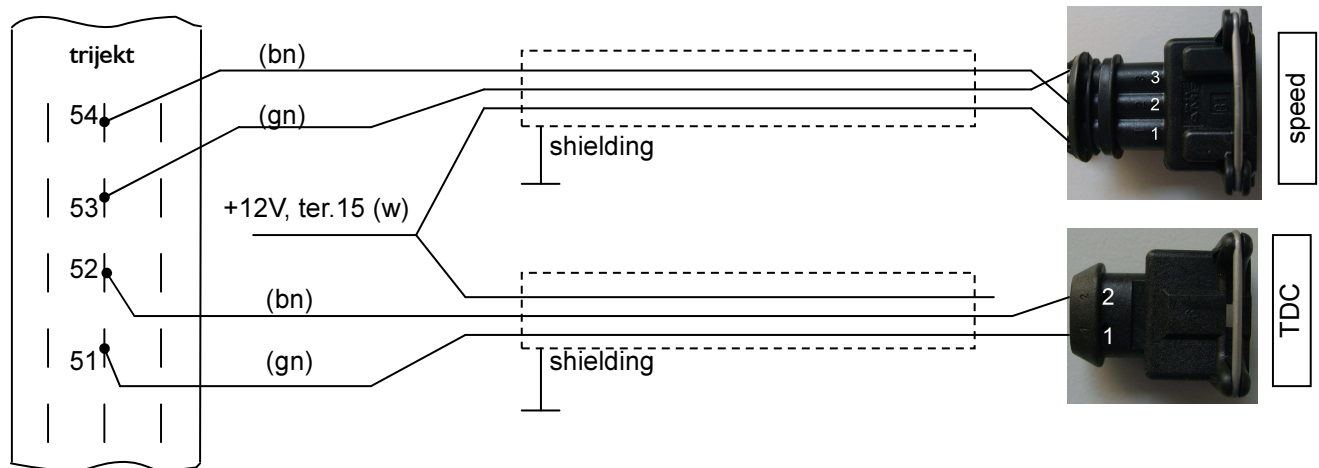

green = signal (ter.51 resp. 53)
 white = 5V (ter.20) alternatively 12V, with corresponding sensor
 brown = signal ground (ter.52 resp. 54)

Optionally connection of inductive- or hall sensors is possible!

**The a/m figure is one example only!
 Connecting double-pole sensors the supply voltage
 (5V or 12V) is not required!**

All connections of speed measurement must be shielded!

**When using hall sensors it is imperative to consider the supply voltage!
 (5Volt or 12Volt)**

2. Installation

2.5 temperature sensors

2.5.1 fixing

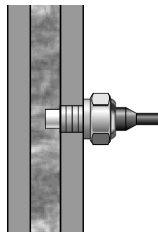

For proper operation of the control unit two temperature sensors are necessary:

- one sensor for the engine temperature.
- one sensor for the induction air temperature.

Engine Temperature

- Install the sensor for the engine temperature directly at the engine block or cylinder head.
- See that there is a good connection between engine and sensor.

Induction Air Temperature

- Install the sensor for the induction air temperature preferably in the way that temperature is measured in direct air flow. If this is not possible from structural point of view, please install the sensor at another place in the zone of front panel or air intake.
- See that the sensor is affected as little as possible by other heat sources (engine, radiator, exhaust pipe).

In principle you can use any kind of temperature sensor. However, its respective properties have to be taken into account when adjusting the values on the control unit.



A temperature sensor must not be used for two instruments at the same time, since this would result in falsified measured values.

2. Installation

2.5.2 electrical connection

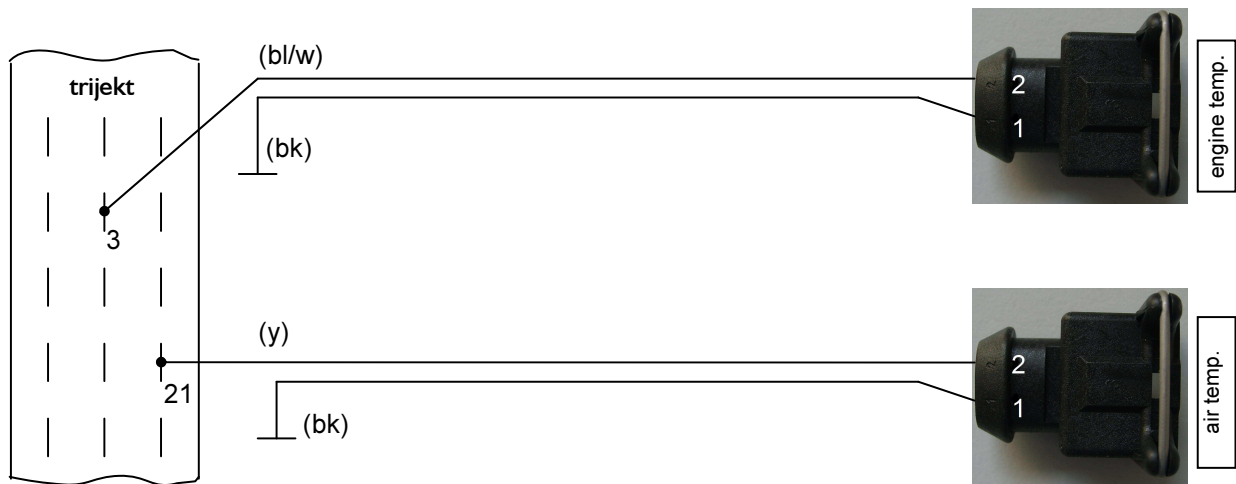

- no parallel connection with other instruments!

2. Installation

2.6 fuel injectors

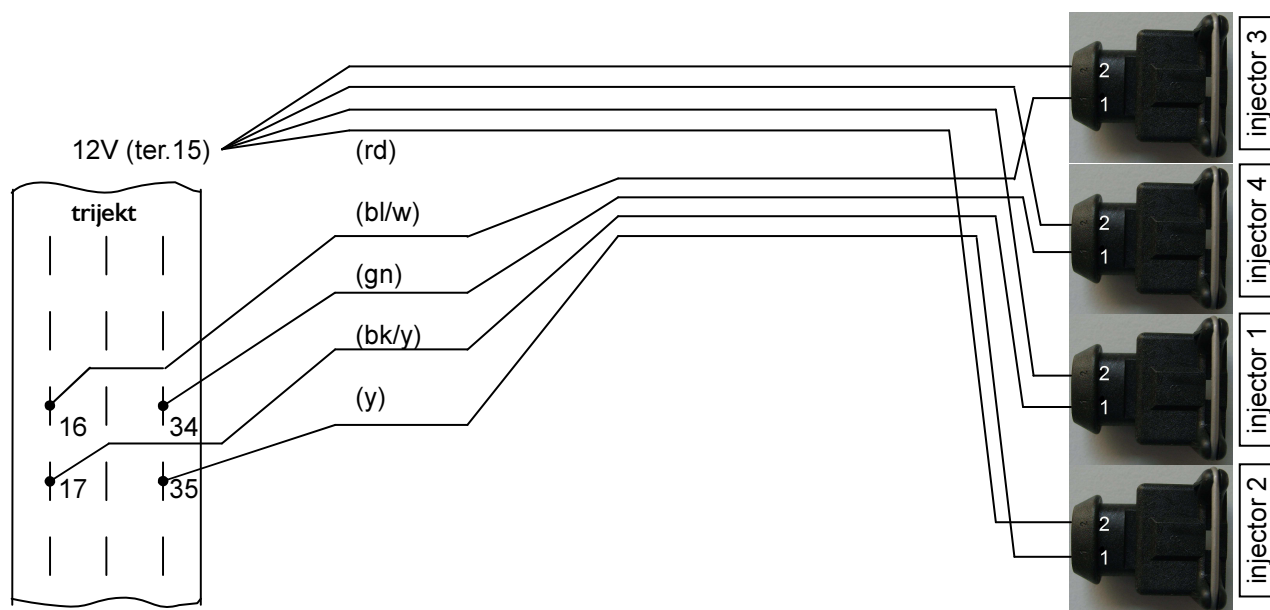

An operation with two fuel injectors per cylinder is also possible.
The injectors 5-8 are connected in the same order as injector 1-4.

Example 1:

4-cyl engine , firing order = 1-3-4-2

One injector per cylinder	cylinder 1	cylinder 3	cylinder 4	cylinder 2
		injector 1	injector 2	injector 3

Example 2:

4-cyl engine with 2 injector-groups , firing order = 1-3-4-2

	cylinder 1	cylinder 3	cylinder 4	cylinder 2
Group 1 (near to the inlet valve)	injector 1	injector 2	injector 3	injector 4
Group 2 (far from the inlet valve)	injector 5	injector 6	injector 7 = ign.6	injector 8 = ign.5

For injector 7 and 8, the ignition outputs 6 and 5 are used.
These outputs may of course not be used simultaneously for the ignition.
The connection of coils is discussed in the next chapter.

2. Installation

2.7 ignition module / ignition driver / ignition coils

2.7.1 fixing

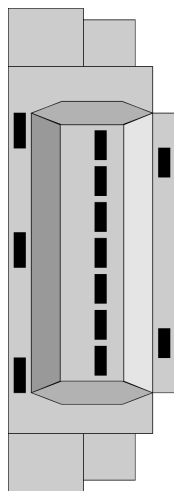

Operating ignition modules produce heat and therefore have to be installed in cooled condition.

For mounting the ignition module please proceed as follows:

Fix the ignition module at an appropriate place, lying flat on the body, so that an optimum heat dissipation is assured. Please take care that the place of installation is not charged by engine- or exhaust heat.

- After installation connect the ignition module to the cable harness of the control unit according to connecting diagram.
- Please consider that all cables except of the **trijekt** control cable have a minimum cross-section of 1.5 mm in order to grant a maximum ignition energy.
- For the ignition module place a separate earth connection, having direct contact to the body. In order to avoid electro-magnetic radiation this earth connection must not be identical to the one for the control unit.



During installation of the ignition module it is imperative to allow for sufficient cooling. Overheating the module can result in misfiring, total failure of ignition and possibly in destructing the module.

2. Installation

2.7.2 electrical connection

Operating with internal ignition drivers

Two internal ignition drivers are already installed in **trijekt** (terminals 41 and 42), where ignition coils can be connected directly.

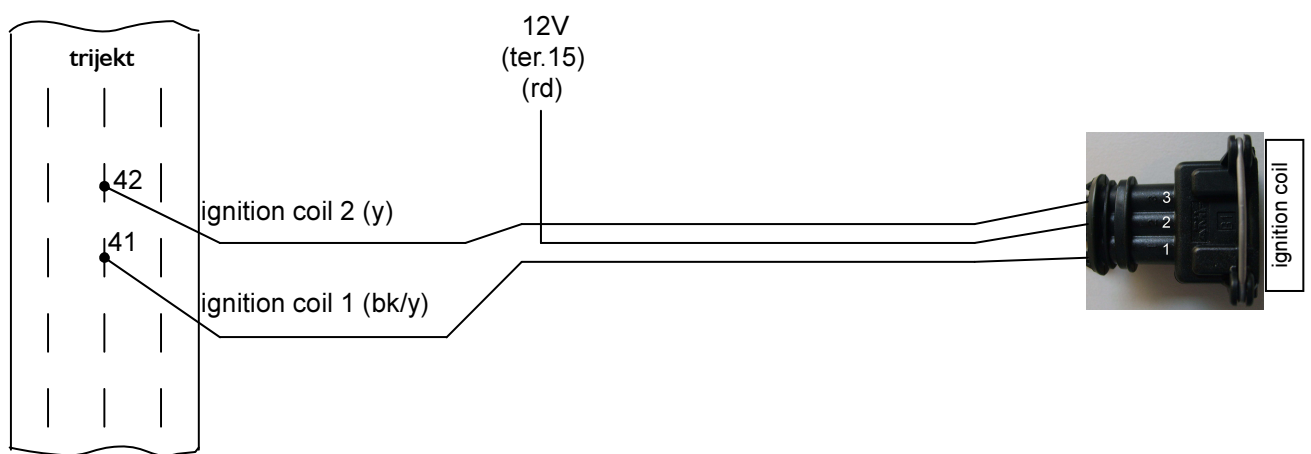

Operation with external ign. drivers (e.g. 3-fold ign. driver Cargo 150387)

You must NEVER connect ignition coils directly to the remaining ignition outputs (terminals 12,13,14,30,31,32)!

DANGER OF DESTRUCTION!

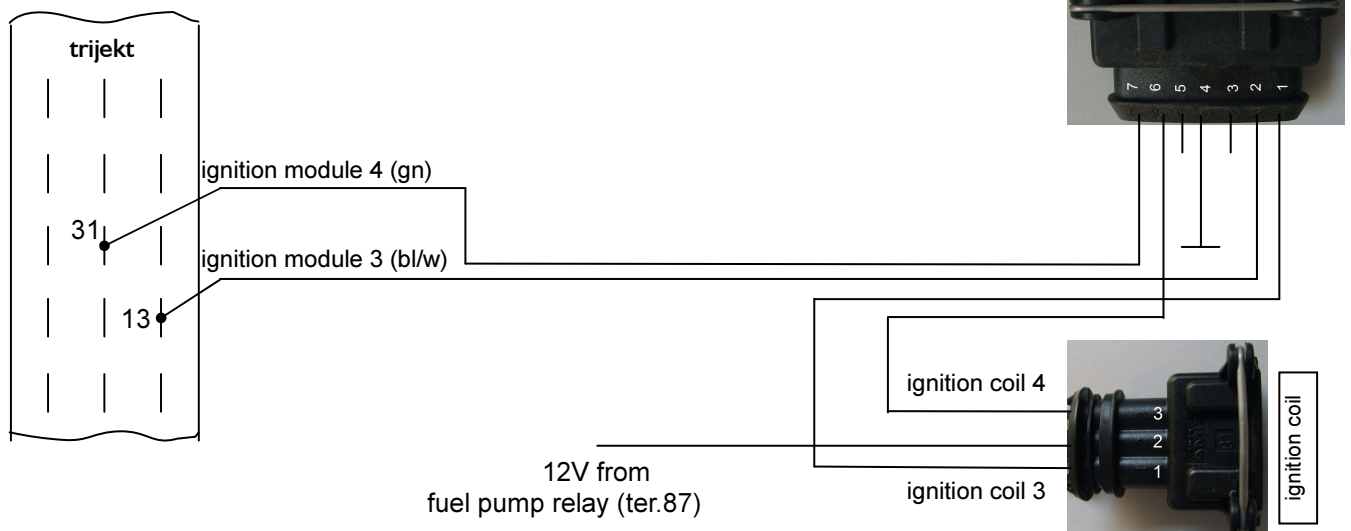

2. Installation

2.8 lambda oxygen sensor

2.8.1 fixing

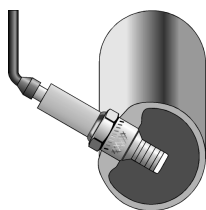

In case that the vehicle being changed over is already equipped with a lambda oxygen sensor as standard, this can be taken over without hesitation.

In case that the lambda oxygen sensor is assembled subsequently, the following criteria should be taken into consideration:

- As close as possible to the engine in order to obtain a fast warming.
- In direct flue gas stream of as many cylinders as possible – i. e. at manifolds behind the combination of two or all cylinders.
- Not in direct airflow in order to assure an adequate operating temperature of the sensor at low ambient temperatures.

For installation please proceed as follows:

- Drill a hole of abt. 18 mm dia. into the exhaust manifold at a suitable point.
- Weld a nut M18 x 1,5 on the drill-hole as entry for the lambda oxygen sensor.
- In particular mind the weld seam to be tight, since leaks in this place and the whole area between engine and Lambda Oxygen Sensor will cause measurement errors and consequently, a maladjustment of **trijekt** to the engine.
- Fix the connecting cable of the lambda oxygen sensor on the body.

Please leave enough cable length for strong vibrations of the exhaust pipe at engine operation.



Already existing systems like series control systems or lambda measuring appliances must not be connected in parallel to the lambda oxygen sensor used for **trijekt**, since this would result in weakening the input signal and thus in measuring errors.

2. Installation

2.8.2 electrical connection

standard lambda oxygen sensor

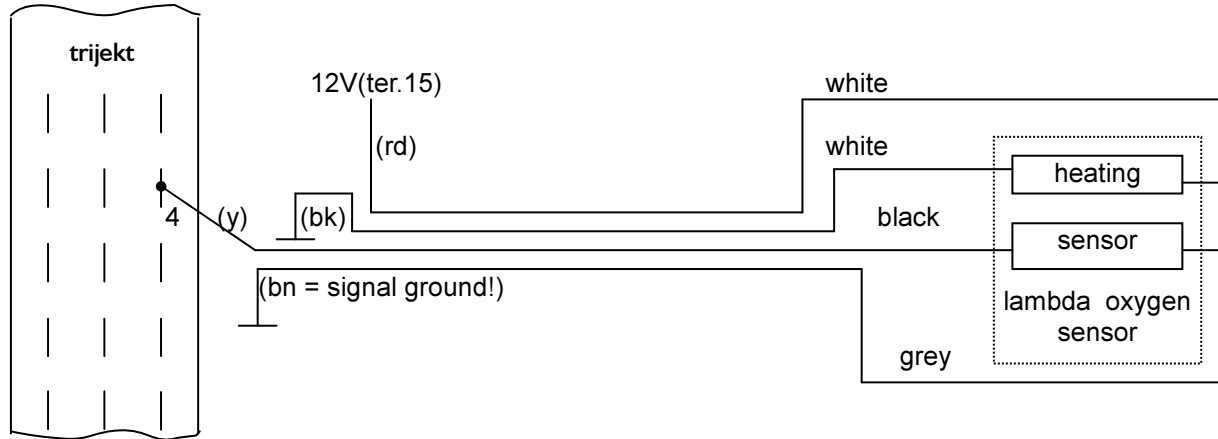

lambda sensors				
connection	single cable	double cable	triple cable	quadruple
signal	black	black	black	black
heating +			white	white
heating -			white	white
ground		white or grey		grey

- use heated sensors only
- install as close as possible to the engine
- preferably comprise all cylinders
- with single restrictor pay special attention to exact synchronisation.

2. Installation

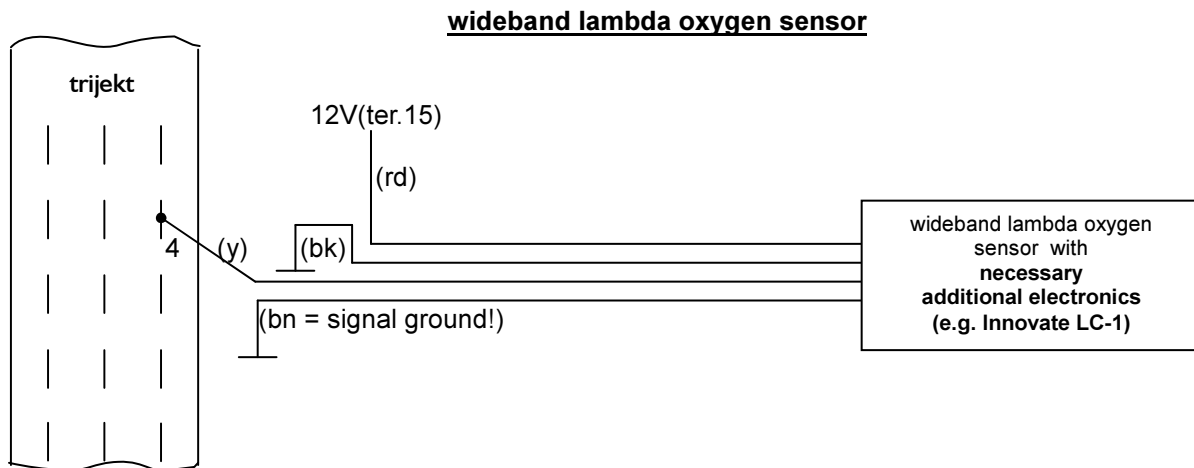

2. Installation

2.9 idle controller

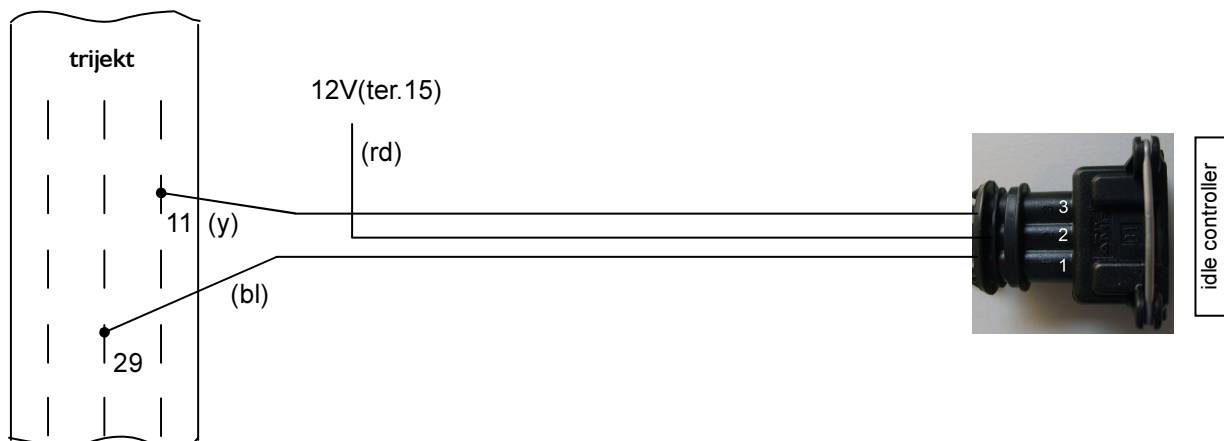

- Pay attention to current consumption – i. e. $R \geq 12 \text{ Ohm}$
- Also double-pole idle controller possible, connection to terminal 29 is omitted.

trijekt Basic:

Operation of these connections is not included in **trijekt Basic**!
We offer you our software extension packet with costs enabling you to use the connections at any time!

When you connect an idle controller, we recommend the use of a free-wheeling diode, directly connected to the idle controller. (When using a 3-pole idle controller, you have to connect two free-wheeling-diodes)

2. Installation

2.10 boost pressure sensor intake manifold sensor (ext. air pressure)

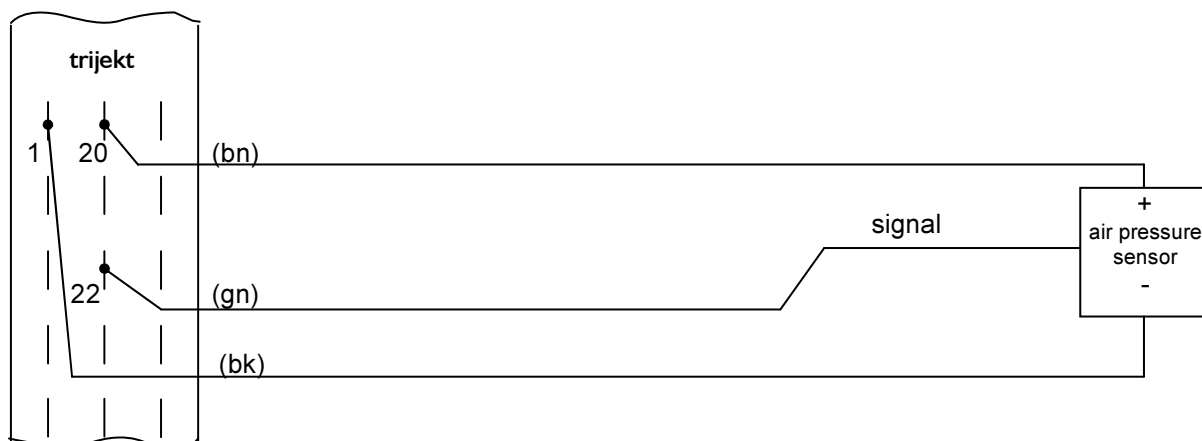

trijekt Basic:

Operation of these connections is not included in **trijekt Basic**!

We offer you our software extension packet with costs enabling you to use the connections at any time!

2. Installation

2.11 air mass sensor

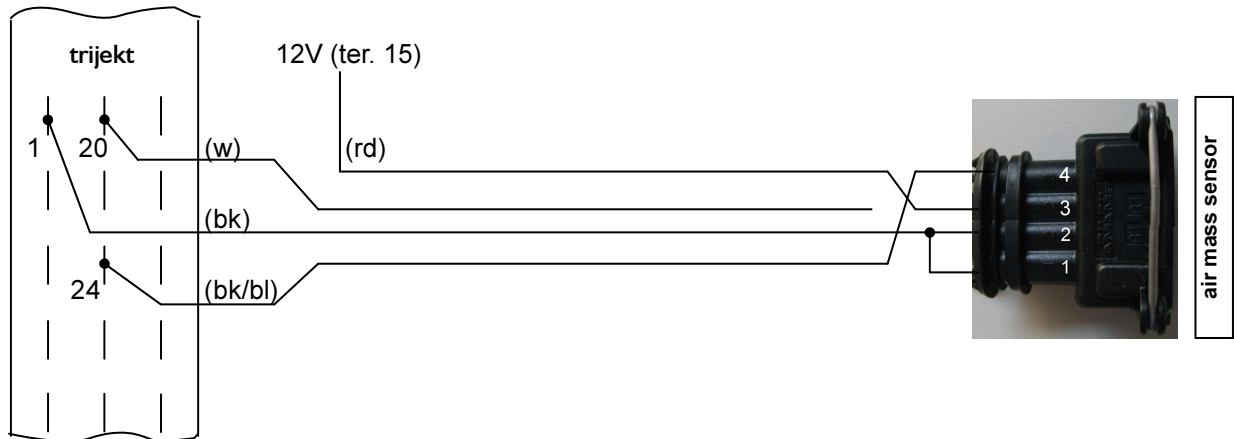

Example of connecting a common 4-pole air mass sensor.

2. Installation

2.12 boost pressure valve

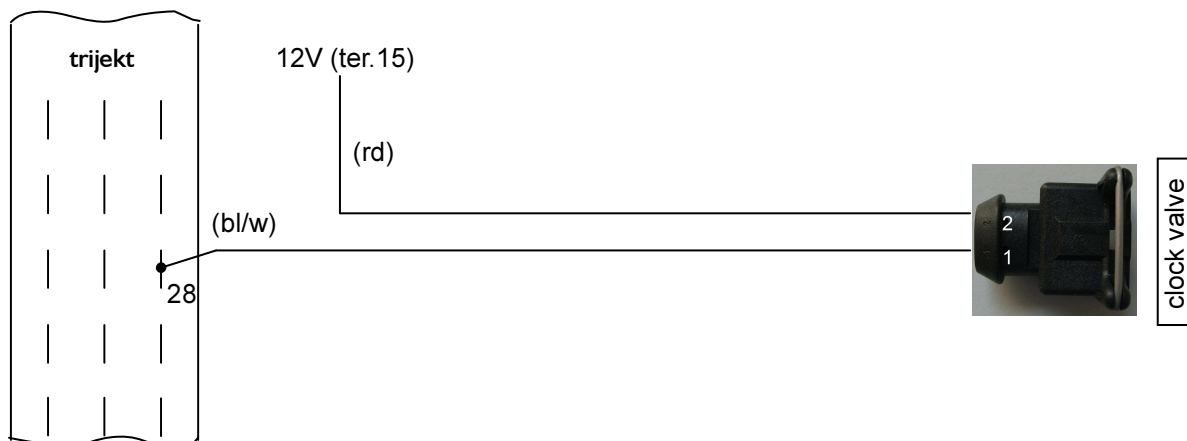

trijekt Basic:

Operation of these connections is not included in **trijekt Basic**!
We offer you our software extension packet with costs enabling you to use the connections at any time!

2. Installation

2.13 accelerator pedal & drive by wire throttle

Available on request only!

2.14 stepping motor

Available on request only!

2. Installation

2.15 CAN-Bus

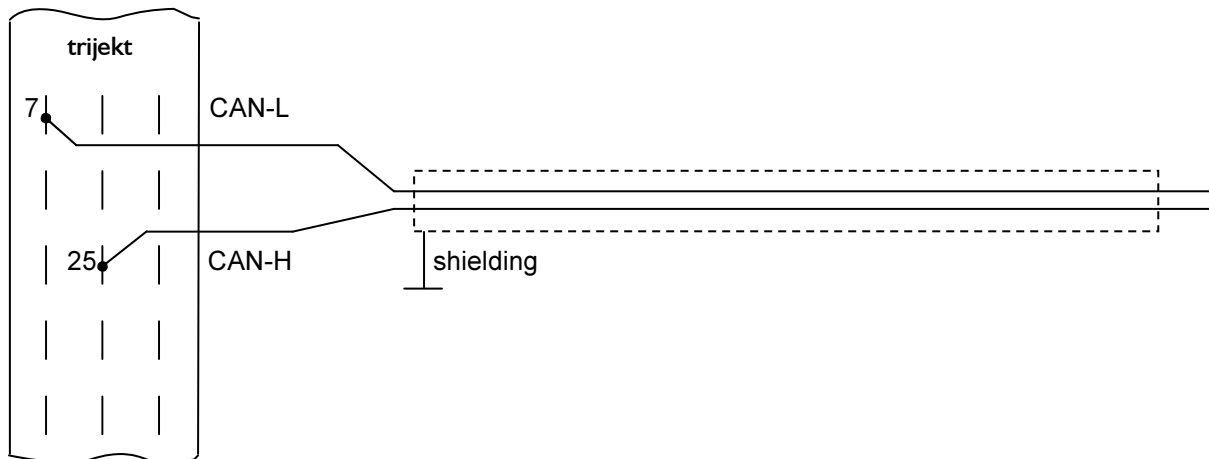

The CAN-bus cable is not present in the prefabricated wiring harness.

2. Installation

2.16 exhaust gas temperature

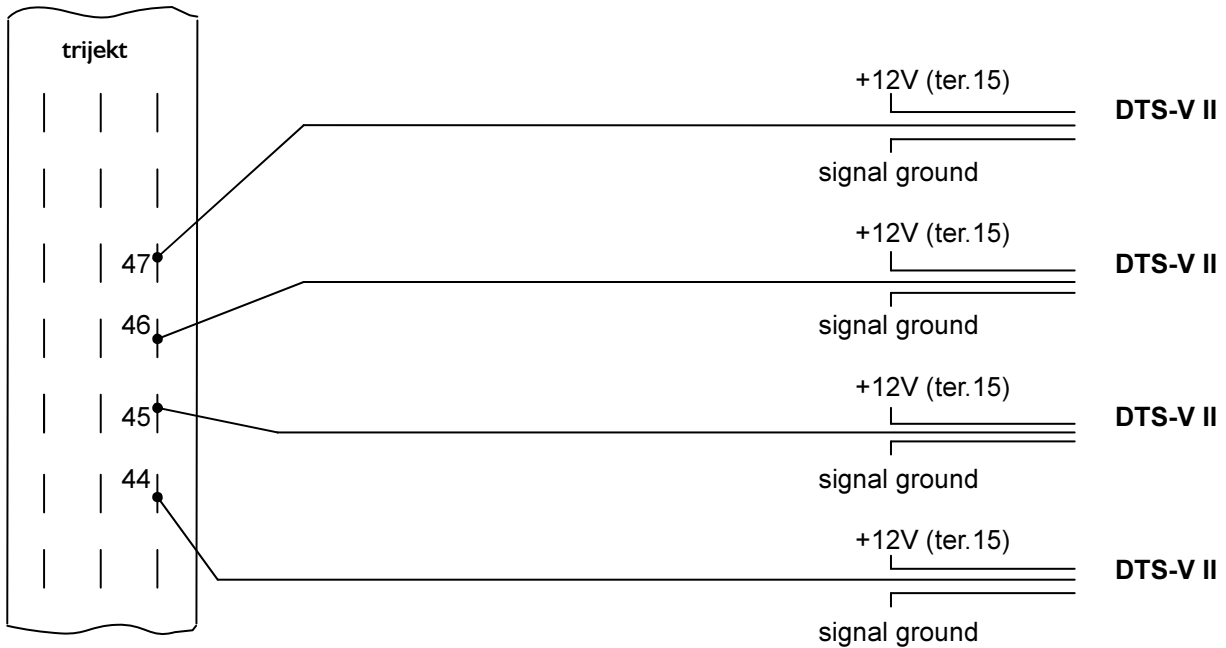

The exhaust gas temperature cables are not present in the prefabricated wiring harness.

The simultaneous connection of 2 exhaust gas temperature sensors is possible.

We recommend the use of the type **DTS-V II** from **delta-r** (www.delta-r.de).

2. Installation

2.17 additional inputs (aux-, gear shift-, function input)

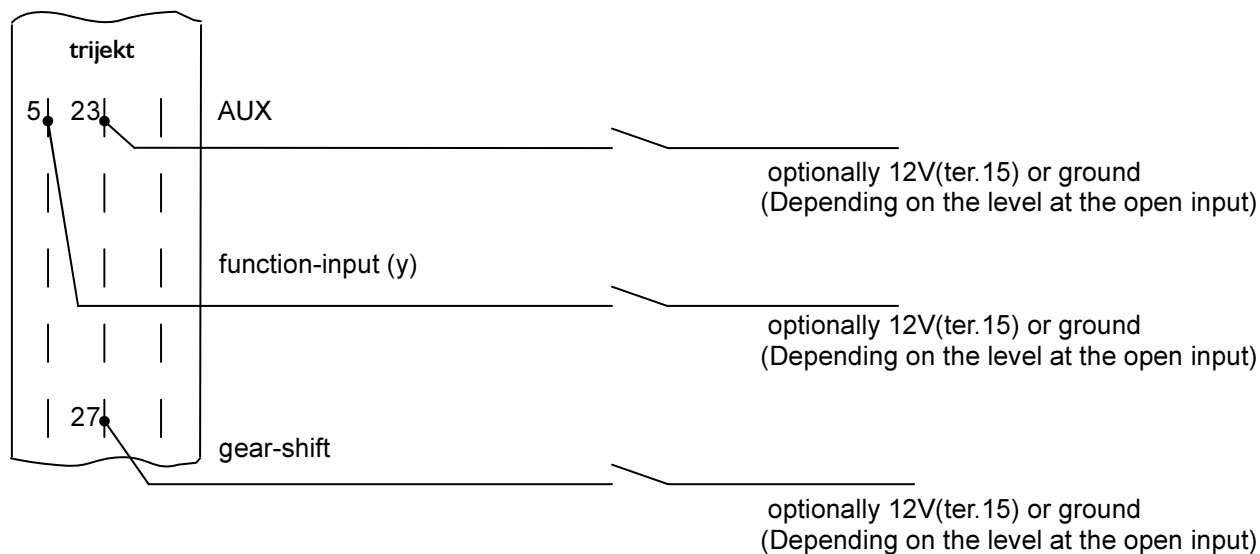

The open gear-shift-input is at low-level.
The open function-input is at low-level.
The open AUX-input is at high-level.

**To change the level at the open input,
you have to connect a 1k resistor to the appropriate target level!**

trijekt Basic:

Operation of these connections is not included in **trijekt Basic**!
We offer you our software extension packet with costs enabling you to use the connections at any time!

The AUX and gear-shift cables are not present in the prefabricated wiring harness.

2. Installation

2.18 switching outputs

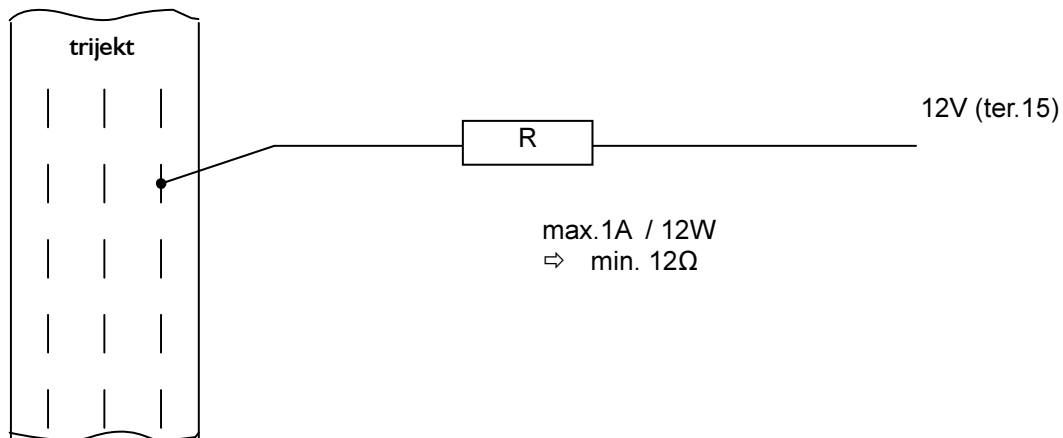

Any output not being required for engine operation can be used as freely programmable switching output.

(If e.g. a 4-cyl. engine is operated, the ignition outputs 5+6 are not required for engine operation.)

Ohm resistive loads as well as inductive loads are possible! (e.g. lamps, relays...)